



يونى ستيل
UNISTEEL
Formwork & Scaffolding

SHOREBRACE SYSTEM

WE ARE FORMING YOUR IDEAS



SHOREBRACE SYSTEM



We are introducing our shorebrace frame system on one basic size combined with one size of cross braces to obtain economic spacing of frames.

Moreover, the telescopic shorebrace frame gives various height adjustments, which can be obtained with a minimum of component parts, to offer high carrying load capacity towers for heavy slab construction at all heights.

TECHNICAL DATA

- Working load: Up to 110 KN per frame.
- Frame size: 180 X 120 cm.
- Telescopic frame size: 165 X 120 cm.
- Cross brace sizes: 90 - 210 cm

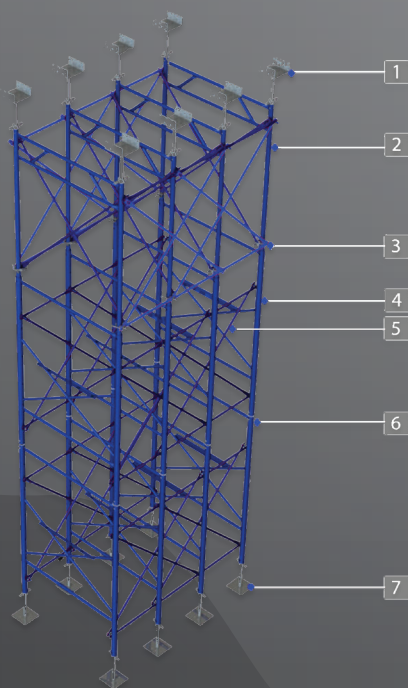

- 1 — U-Head Jack
- 2 — Telescopic frame [1.65 X 1.2m]
- 3 — Half coupler with pin
- 4 — Shore-Brace frame [1.8 X 1.2m]
- 5 — Cross brace
- 6 — Frame connector, rivet pin & spring clip
- 7 — Post head jack

APPLICATIONS

- Traditional / Tower-based shoring.
- Table-form shoring
- Bridge & tunnel shoring.
- Back-propping
- Gantries
- Working platforms

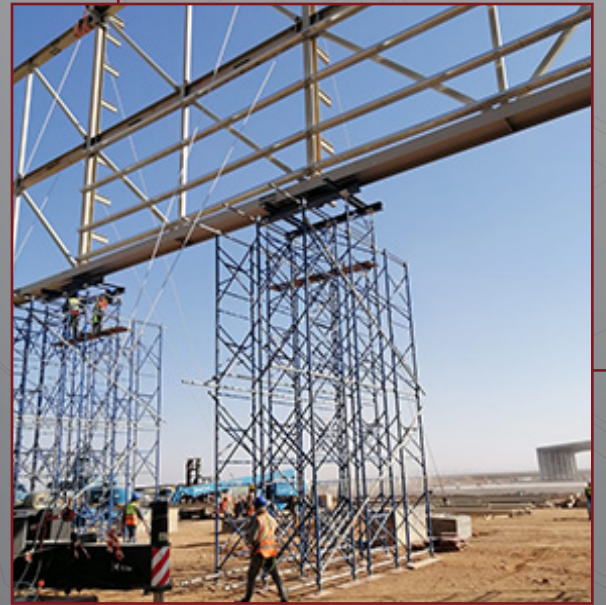

MAIN COMPONENTS ;

SHORE BRACE FRAME H

Size	Weight Kg	Code No
120cm x 180cm	28.50	600-001

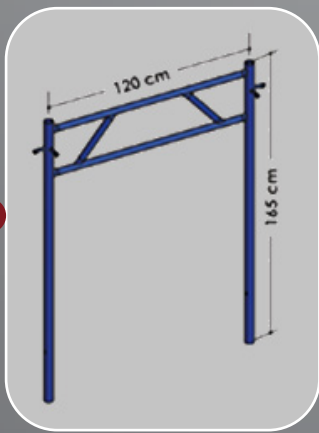
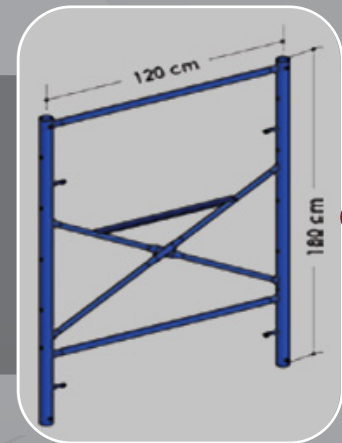

TELESCOPIC FRAME

Size	Weight Kg	Code No
120cm x 165cm	19.64	600-002

CROSS BRACE

Size (X)	Weight Kg	Code No
Cross Brace 0.6m	3.77	600-009
Cross Brace 0.9m	4.07	600-005
Cross Brace 1.2m	4.57	600-006
Cross Brace 1.5m	5.15	600-007
Cross Brace 1.8m	5.77	600-008
Cross Brace 2.1m	6.43	600-010

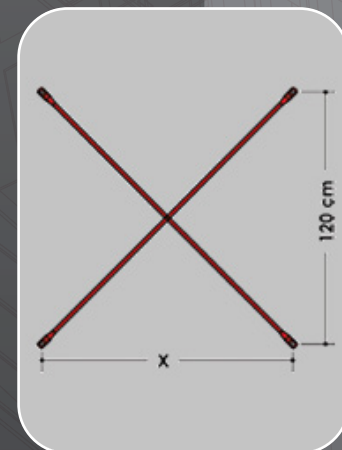

SHORE BRACE FRAME CONNECTOR

Size	Weight Kg	Code No
---	0.50	600-004

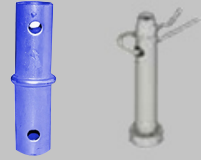

SHORE BARCE COUPLER

Size	Weight Kg	Code No
2.0 "	1.59	600-015

POST HEAD JACK SOLID

Size	Weight Kg	Code No
34 mm	7.48	600-013



U - HEAD JACK SOLID

Size	Weight Kg	Code No
34 mm	7.82	600-014



Contact Us

✉ Info@unisteel.com.sa

🌐 www.unisteel.com.sa

📞 920000864

